



VIBRATION SENSOR

BL-600 SERIES

BL-600: SMT Installation

BL-600DIP: Pin-type installation

Micro-vibration detection sensor switch

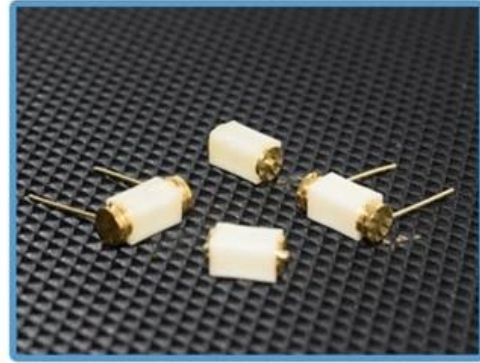

BL-600 series

Vibration sensor switch

■Application

Vibration detection

Displacement detection

Vibration alarm

Smart open

■Introduction

1. BL-600 series is a micro-vibration induction sensor switch.
2. Simple interface - no signal conditioning required.
3. Non-directionality requires vibration-sensing switch, 360-degree omnidirectionality can detect vibration.
4. The switch is assembled with ROHS environmental protection materials and passed ROHS certification.
5. Switch can be purchased: SMD type installation: BL-600 pin type installation: BL-600DIP

Suitable for all kinds of alarms, LEDs, smart homes, vibration-triggered products.

CLASSIFICATION

BL-600 Series Vibration sensor





PARAMETER

BL-600 Series Vibration sensor

Use voltage range	Use current range	Default state	Trigger method	Conductive time	Product life
<12V	<20mA	Closed (uncertain)	Vibration	~2ms	above 50000 hours

FEATURES

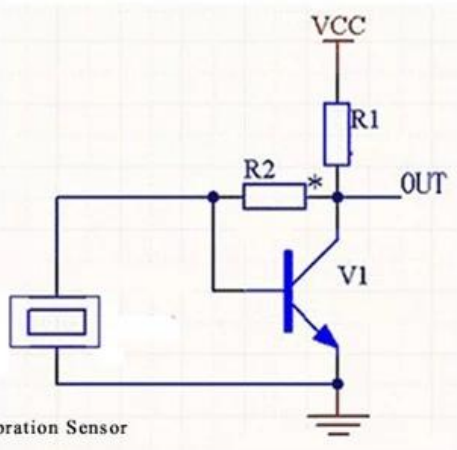
BL-600 Series Vibration sensor

Test circuit diagram	Trigger status
 <p>Vibration Sensor</p>	<div data-bbox="925 1433 1284 1691"> <p>chatters closed to open</p>  </div> <div data-bbox="925 1702 1284 1960">  </div>

DIMENSIONS

BL-600 Series Vibration sensor

BL-600 Series PRODUCT SIZE

Unit=mm

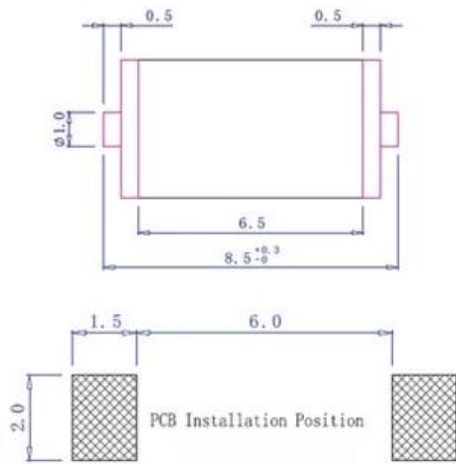

BL-600

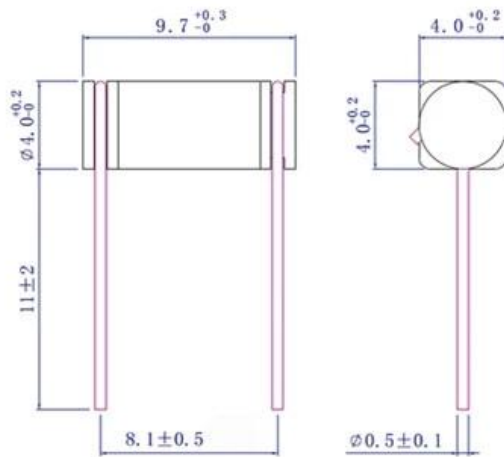
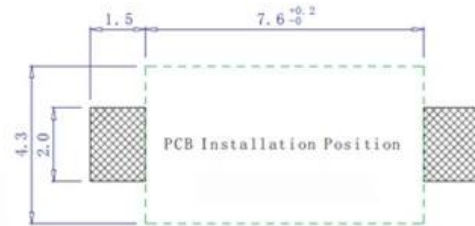

BL-600DIP

