

Data Sheet

3D TouchPrint[®] *Optical Fingerprint Recognition* **EMBEDDED** Module

GTM-5110C3



2013/03/26

V1.1

Contents

1.	Concept.....	4
2.	Protocol: Packet Structure	6
	Command Packet (Command)	6
	Response Packet (Acknowledge).....	6
	Data Packet (Data).....	7
3.	Protocol: Commands Summary.....	8
4.	Protocol: Error Codes	10
5.	Protocol: Command Details	12
	5.1. Initialization(Open)	12
	5.2. Termination(Close).....	14
	5.3. Fast searching of the device(UsbInternalCheck).....	14
	5.4. CMOS LED control(CmosLed)	15
	5.5. Changing UART baud rate (ChangeBaudrate)	16
	5.6. Get enrolled fingerprint count(GetEnrollCount)	17
	5.7. Check enrollment status(CheckEnrolled).....	17
	5.8. Start an enrollment(EnrollStart)	18
	5.9. Make 1st template for an enrollment(Enroll1)	18
	5.10. Make 2nd template for an enrollment(Enroll2)	19
	5.11. Make 3rd template for an enrollment, merge three templates(Enroll3).....	19
	5.12. Check finger pressing status(IsPressFinger)	21
	5.13. Delete one fingerprint(DeleteID)	22
	5.14. Delete all fingerprints(DeleteAll)	22
	5.15. 1:1 Verification(Verify)	23
	5.16. 1:N Identification(Identify).....	23
	5.17. 1:1 Verification of Template(VerifyTemplate)	24
	5.18. 1:N Identification of Template(IdentifyTemplate)	25
	5.19. Capture fingerprint(CaptureFinger)	26
	5.20. Make Template(MakeTemplate).....	27
	5.21. Get fingerprint image(GetImage)	28
	5.22. Get raw image(GetRawImage)	29
	5.23. Get template(GetTemplate)	29
	5.24. Set template(SetTemplate).....	30

5.25.	Start database download, obsolete(<i>GetDatabaseStart</i>)	30
5.26.	End database download, obsolete(<i>GetDatabaseEnd</i>)	31
5.27.	Upgrade Firmware(<i>UpgradeFirmware</i>)	32
5.28.	Upgrade ISO CD Image(<i>UpgradeISOCDImage</i>)	32
5.29.	Set IAP Mode(<i>SetIAPMode</i>)	32
6.	Protocol: Flowchart, description	33
6.1	Capture of the fingerprint image	33
6.2	Identifying and Verifying	33
6.3	Enrollment	33
7.	PC Demo	35
8.	Mechanical Dimensions	38

1. Concept

This device is one chip module with;

- fingerprint algorithm
- *GyngyTech* optical sensor

The major functions are the followings.

- High-accuracy and high-speed fingerprint identification technology
- Ultra-thin optical sensor
- 1:1 verification, 1:N identification
- downloading fingerprint image from the device
- Reading & writing fingerprint template(s) from/to the device
- Simple UART & USB communication protocol

Technical Specification

Item	Value
CPU	ARM Cortex M3 Core (Holtek HT32F2755)
Sensor	<i>GingyTech</i> optical Sensor
Effective area of the Sensor	14 x 12.5(mm)
Image Size	202 x 258 Pixels
Resolution	450 dpi
The maximum number of fingerprints	200 fingerprints
Matching Mode	1:1, 1:N
The size of template	496 Bytes (template) + 2 Bytes (checksum)
Communication interface	UART, default baud rate = 9600bps after power on USB Ver1.1, Full speed
False Acceptance Rate (FAR)	< 0.001%
False Rejection Rate(FRR)	< 0.1%
Enrollment time	< 3 sec (3 fingerprints)
Identification time	< 1.0 sec (200 fingerprints)
Operating voltage	DC 3.3~6V
Operating current	< 130mA

Operating environment	Temperature	-20°C ~ +60°C
	Humidity	20% ~ 80%
Storage environment	Temperature	-20°C ~ +60°C
	Humidity	10% ~ 80%

2. Protocol: Packet Structure

(Multi-byte item is represented as Little Endian.)

Command Packet (Command)

OFFSET	ITEM	TYPE	DESCRIPTION
0	0x55	BYTE	Command start code1
1	0xAA	BYTE	Command start code2
2	<i>Device ID</i>	WORD	Device ID: default is 0x0001, always fixed
4	<i>Parameter</i>	DWORD	Input parameter
8	<i>Command</i>	WORD	Command code
10	<i>Check Sum</i>	WORD	Check Sum (byte addition) $OFFSET[0]+...+OFFSET[9]=Check\ Sum$

Response Packet (Acknowledge)

OFFSET	ITEM	TYPE	DESCRIPTION
0	0x55	BYTE	Response start code1
1	0xAA	BYTE	Response start code2
2	<i>Device ID</i>	WORD	Device ID: default is 0x0001, always fixed
4	<i>Parameter</i>	DWORD	Response == 0x30: (ACK) Output Parameter Response == 0x31: (NACK) Error code
8	<i>Response</i>	WORD	0x30: Acknowledge (ACK). 0x31: Non-acknowledge (NACK).
10	<i>Check Sum</i>	WORD	Check Sum (byte addition) $OFFSET[0]+...+OFFSET[9]=Check\ Sum$

Data Packet (Data)

OFFSET	ITEM	TYPE	DESCRIPTION
0	0x5A	BYTE	Data start code1
1	0xA5	BYTE	Data start code2
2	<i>Device ID</i>	WORD	Device ID: default is 0x0001, always fixed
4	<i>Data</i>	N BYTES	N bytes Data The size is pre-defined per protocol stage
4+N	<i>Check Sum</i>	WORD	Check Sum (byte addition) $OFFSET[0]+...+OFFSET[4+N-1]=Check\ Sum$

3. Protocol: Commands Summary

In a command packet *Command* can be one of below.

Number (HEX)	Alias	Description
01	<i>Open</i>	Initialization
02	<i>Close</i>	Termination
03	<i>UsbInternalCheck</i>	Check if the connected USB device is valid
04	<i>ChangeBaudrate</i>	Change UART baud rate
05	<i>SetIAPMode</i>	Enter IAP Mode In this mode, FW Upgrade is available
12	<i>CmosLed</i>	Control CMOS LED
20	<i>GetEnrollCount</i>	Get enrolled fingerprint count
21	<i>CheckEnrolled</i>	Check whether the specified ID is already enrolled
22	<i>EnrollStart</i>	Start an enrollment
23	<i>Enroll1</i>	Make 1 st template for an enrollment
24	<i>Enroll2</i>	Make 2 nd template for an enrollment
25	<i>Enroll3</i>	Make 3 rd template for an enrollment, merge three templates into one template, save merged template to the database
26	<i>IsPressFinger</i>	Check if a finger is placed on the sensor
40	<i>DeleteID</i>	Delete the fingerprint with the specified ID
41	<i>DeleteAll</i>	Delete all fingerprints from the database
50	<i>Verify</i>	1:1 Verification of the capture fingerprint image with the specified ID
51	<i>Identify</i>	1:N Identification of the capture fingerprint image with the database
52	<i>VerifyTemplate</i>	1:1 Verification of a fingerprint template with the specified ID
53	<i>IdentifyTemplate</i>	1:N Identification of a fingerprint template with the database

Number (HEX)	Alias	Description
60	<i>CaptureFinger</i>	Capture a fingerprint image(256x256) from the sensor
61	<i>MakeTemplate</i>	Make template for transmission
62	<i>GetImage</i>	Download the captured fingerprint image(256x256)
63	<i>GetRawImage</i>	Capture & Download raw fingerprint image(320x240)
70	<i>GetTemplate</i>	Download the template of the specified ID
71	<i>SetTemplate</i>	Upload the template of the specified ID
72	<i>GetDatabaseStart</i>	Start database download, obsolete
73	<i>GetDatabaseEnd</i>	End database download, obsolete
80	<i>UpgradeFirmware</i>	Not supported
81	<i>UpgradeISOCDImage</i>	Not supported
30	<i>Ack</i>	Acknowledge.
31	<i>Nack</i>	Non-acknowledge.

4. Protocol: Error Codes

When response packet is Non-acknowledge, *Parameter* represents an error code as below.

NACK Parameter	Value	Description
NACK_TIMEOUT	0x1001	Obsolete , capture timeout
NACK_INVALID_BAUDRATE	0x1002	Obsolete , Invalid serial baud rate
NACK_INVALID_POS	0x1003	The specified ID is not between 0~199
NACK_IS_NOT_USED	0x1004	The specified ID is not used
NACK_IS_ALREADY_USED	0x1005	The specified ID is already used
NACK_COMM_ERR	0x1006	Communication Error
NACK_VERIFY_FAILED	0x1007	1:1 Verification Failure
NACK_IDENTIFY_FAILED	0x1008	1:N Identification Failure
NACK_DB_IS_FULL	0x1009	The database is full
NACK_DB_IS_EMPTY	0x100A	The database is empty
NACK_TURN_ERR	0x100B	Obsolete , Invalid order of the enrollment (The order was not as: EnrollStart -> Enroll1 -> Enroll2 -> Enroll3)
NACK_BAD_FINGER	0x100C	Too bad fingerprint
NACK_ENROLL_FAILED	0x100D	Enrollment Failure
NACK_IS_NOT_SUPPORTED	0x100E	The specified command is not supported
NACK_DEV_ERR	0x100F	Device Error, especially if Crypto-Chip is trouble
NACK_CAPTURE_CANCELED	0x1010	Obsolete , The capturing is canceled
NACK_INVALID_PARAM	0x1011	Invalid parameter
NACK_FINGER_IS_NOT_PRESSED	0x1012	Finger is not pressed

Duplicated ID	0 - 199	There is duplicated fingerprint (while enrollment or setting template), This error describes just duplicated ID
---------------	---------	---

5. Protocol: Command Details

5.1. Initialization(*Open*)

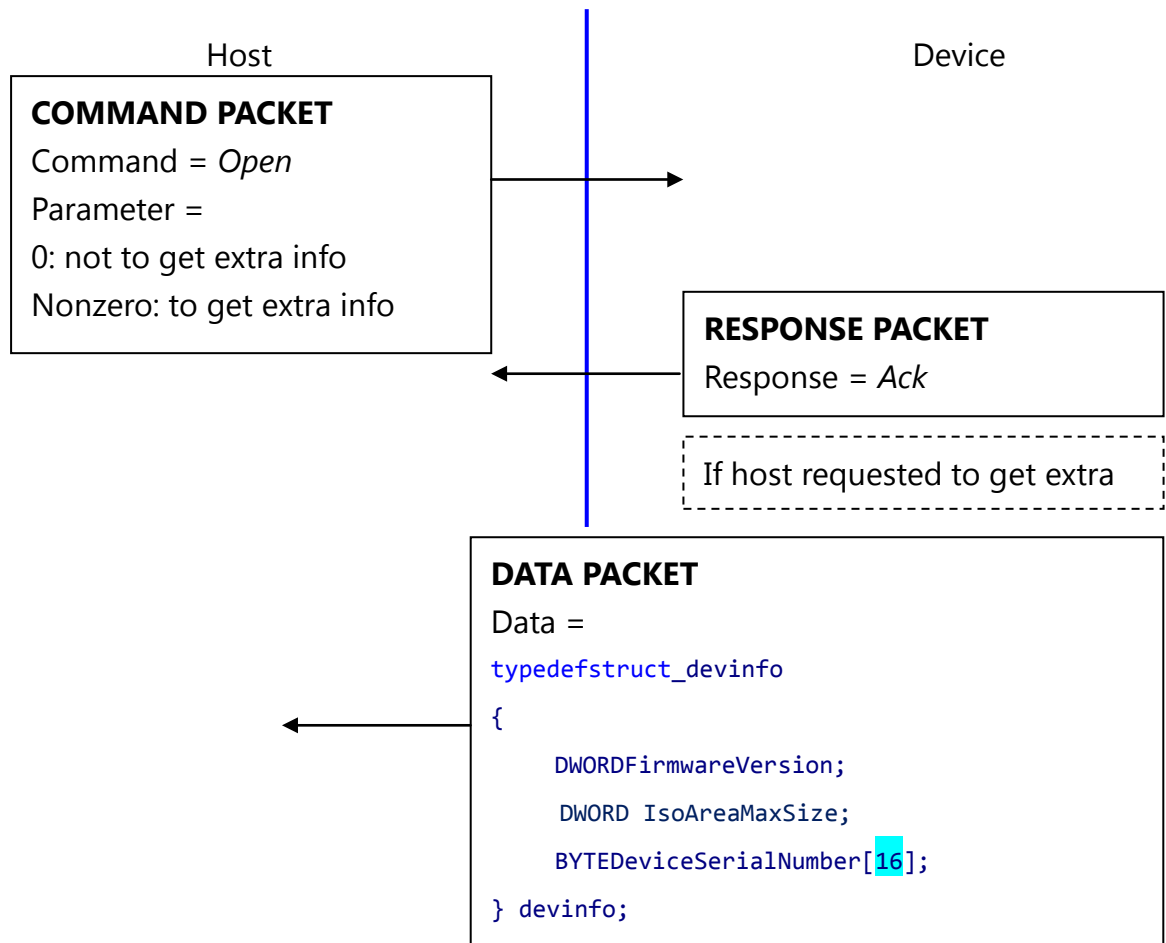

Open command is used to initialize the device; especially it gets device's static info.

Description of *devinfo* structure

Field	Sample	Description
<i>FirmwareVersion</i>	FirmwareVersion: 20120225	Firmware version
<i>IsoAreaMaxSize</i>	IsoAreaMaxSize: 0 KB	Maximum size of ISO CD image
<i>DeviceSerialNumber</i>	DeviceSN: EF15EF4016C66250-888F1A4139000000	Unique serial number of the device

If the Device's Serial Number is zero, then there is no guarantee for stable operation of the device.

5.2. Termination(*Close*)

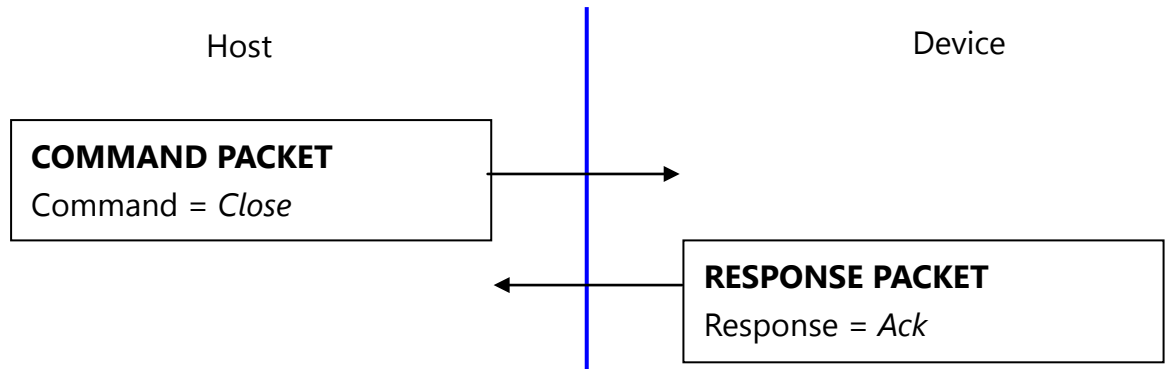

Close command does nothing.

5.3. Fast searching of the device(*UsbInternalCheck*)

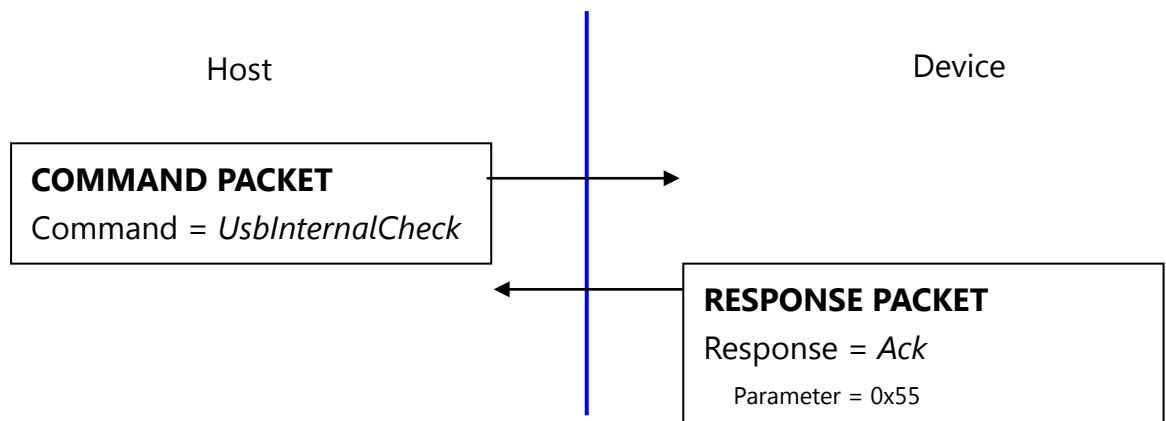

The device operates as removable CD drive. If another removable CD drive exists in the system, connection time maybe will be long. To prevent this, *UsbInternalCheck* command is used for fast searching of the device.

5.4. CMOS LED control(CmosLed)

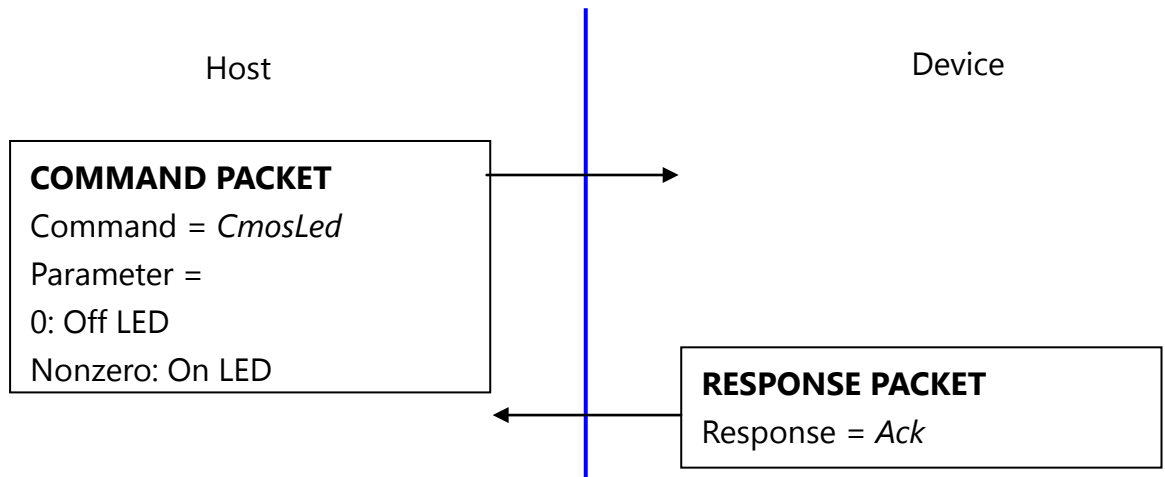

Default state of CMOS (Sensor) LED is OFF state.

(But while booting, LED blinks once, this says the LED is OK.)

Therefore, please issue LED ON command prior to any capture.

5.5. Changing UART baud rate (*ChangeBaudrate*)

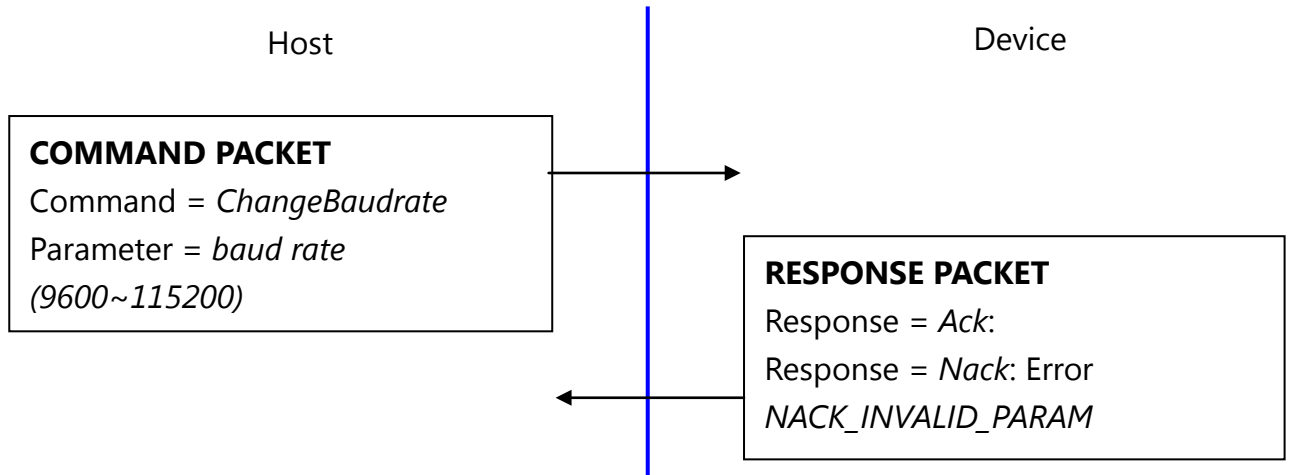

This command changes the UART baud rate at the run-time.

The device initializes its UART baud rate to 9600 bps after power on.

5.6. Get enrolled fingerprint count(*GetEnrollCount*)

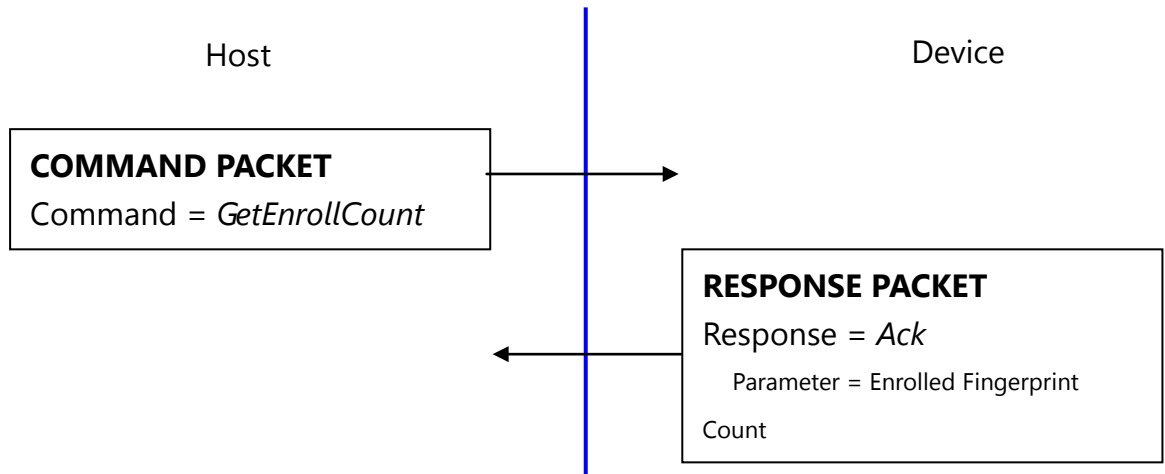

5.7. Check enrollment status(*CheckEnrolled*)

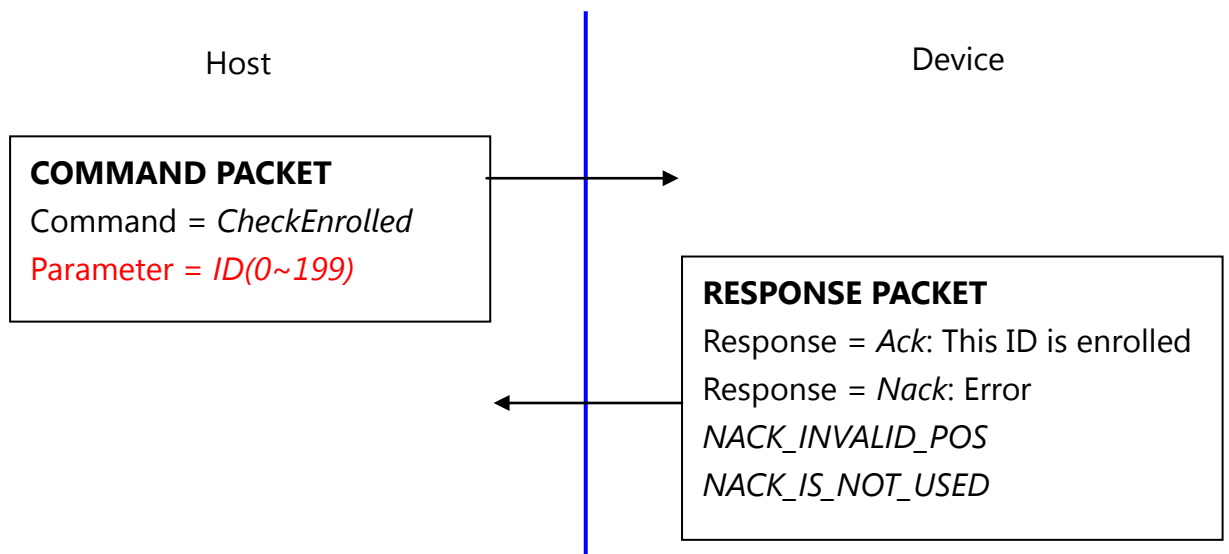

5.8. Start an enrollment(*EnrollStart*)

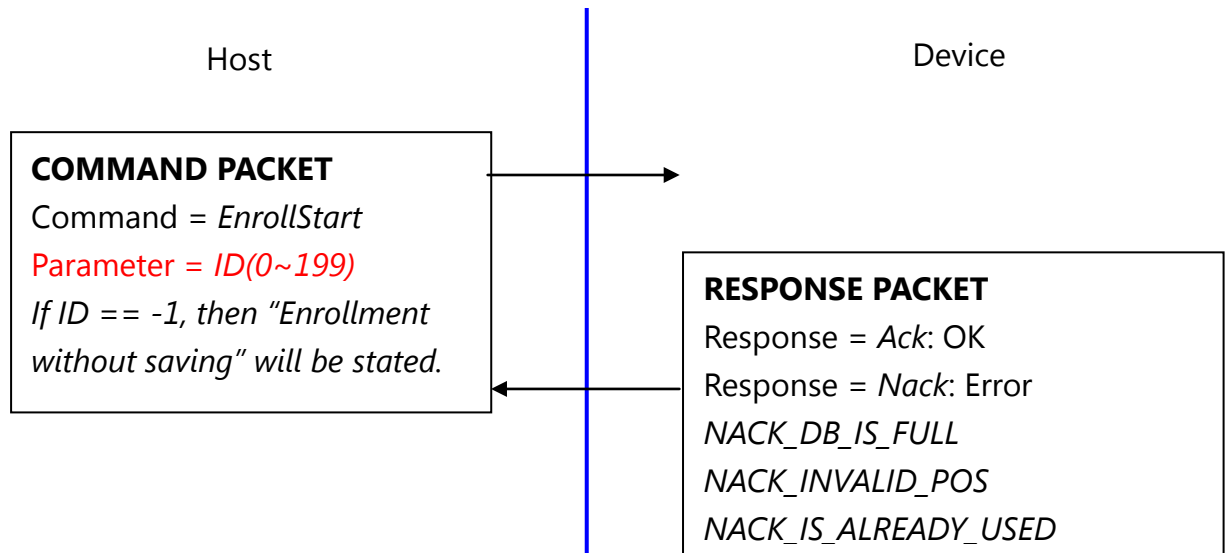

5.9. Make 1st template for an enrollment(*Enroll1*)

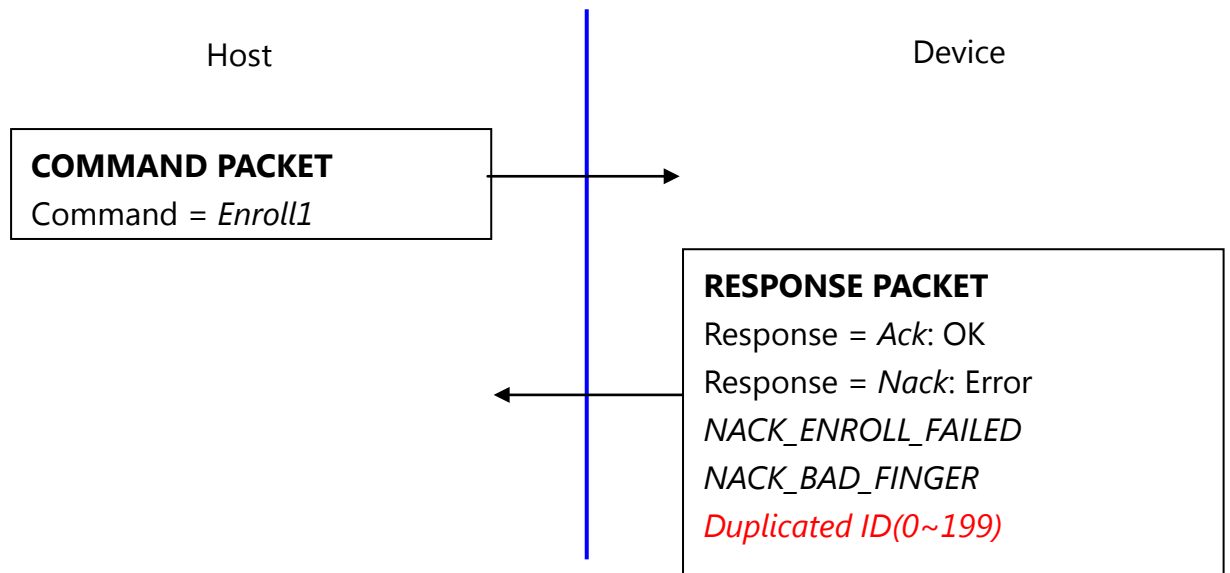

5.10. Make 2nd template for an enrollment(*Enroll2*)

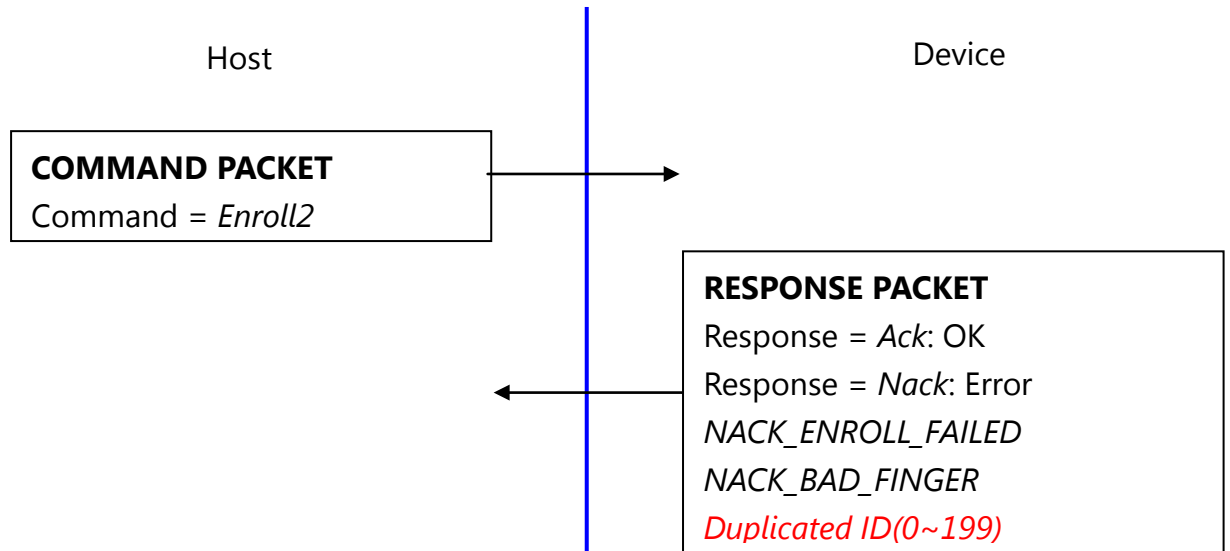

5.11. Make 3rd template for an enrollment, merge three templates(*Enroll3*)

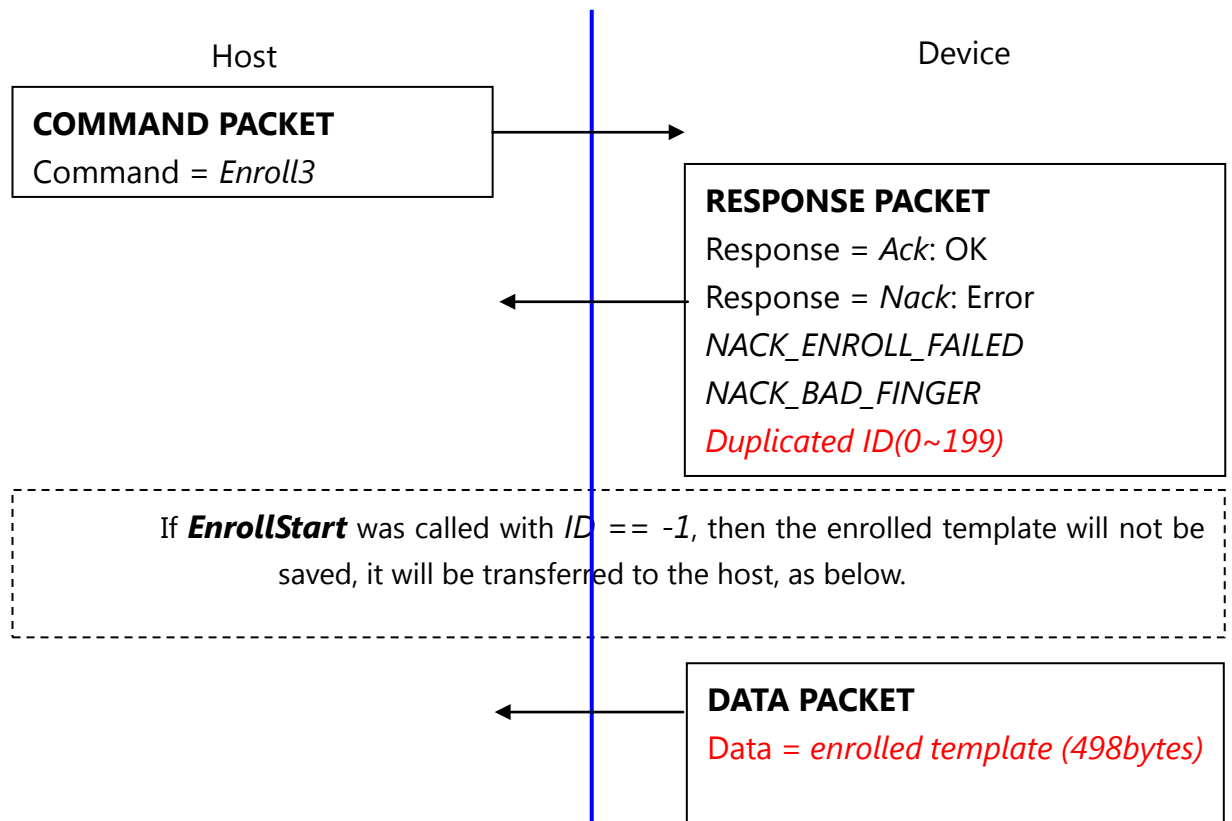

To enroll a fingerprint, the host must issue above 4 commands, later chapter describes how to organize these commands.

5.12. Check finger pressing status(*IsPressFinger*)

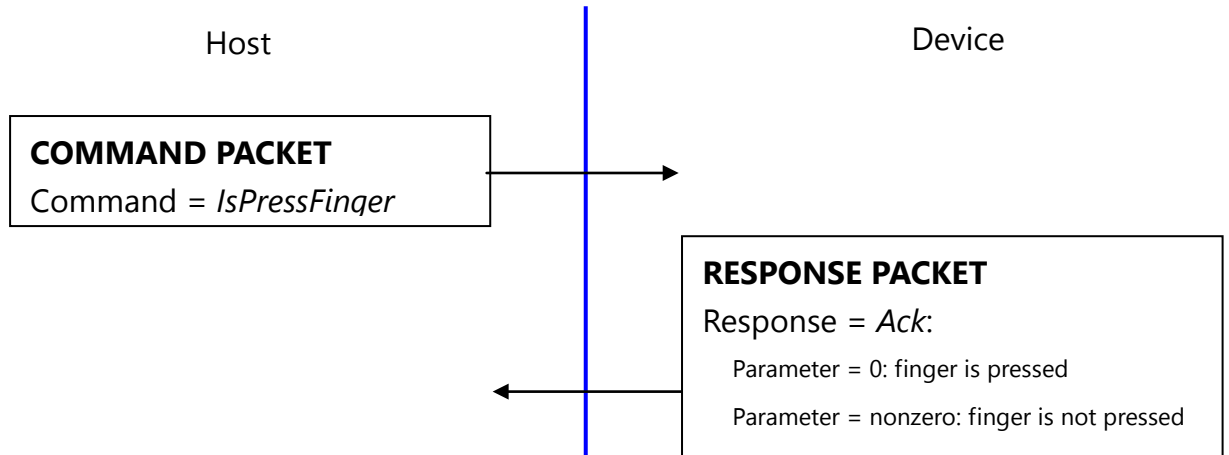

This command is used while enrollment, the host waits to take off the finger per enrollment stage.

5.13. Delete one fingerprint(*DeleteID*)

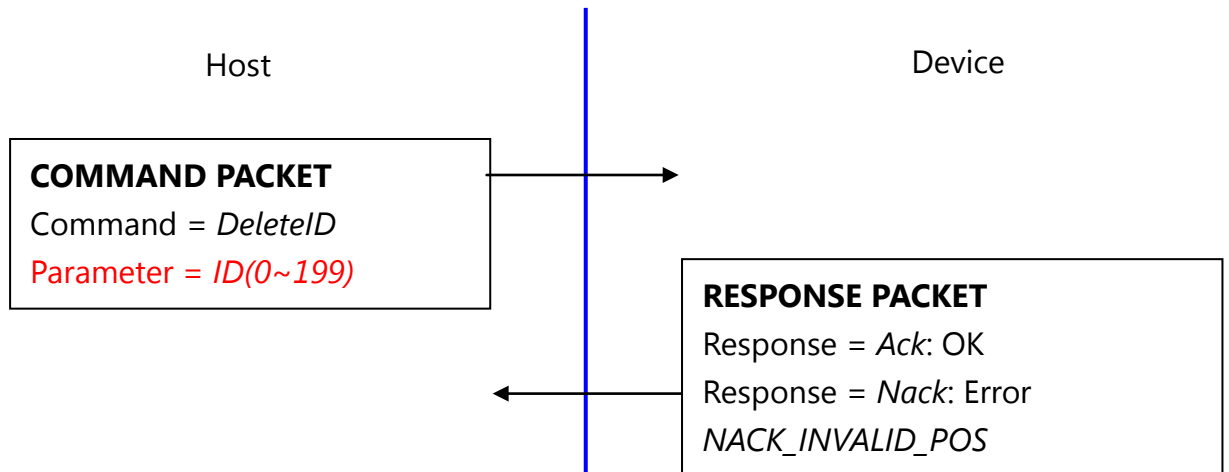

5.14. Delete all fingerprints(*DeleteAll*)

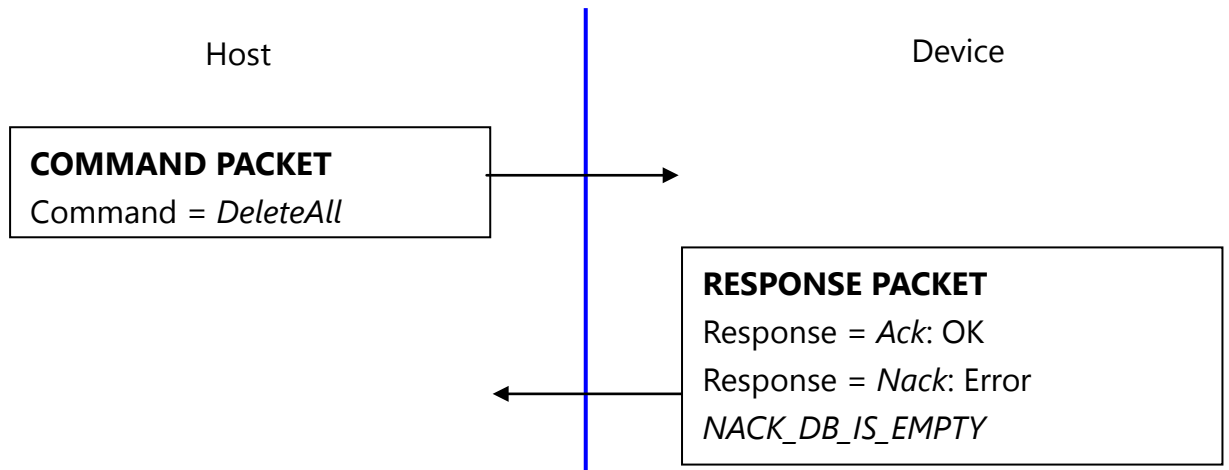

5.15. 1:1 Verification(*Verify*)

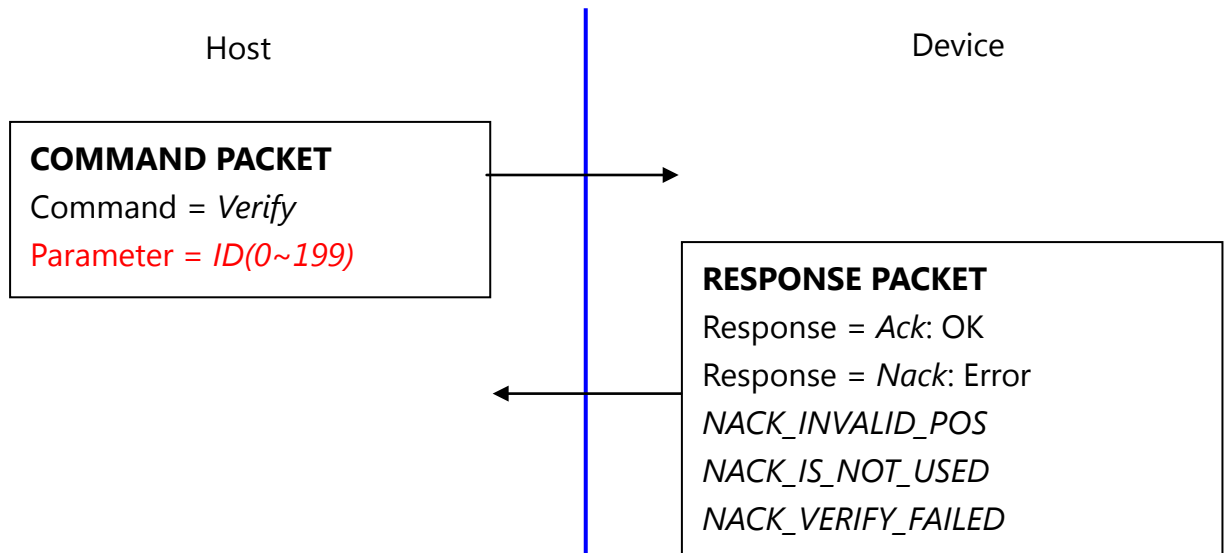

5.16. 1:N Identification(*Identify*)

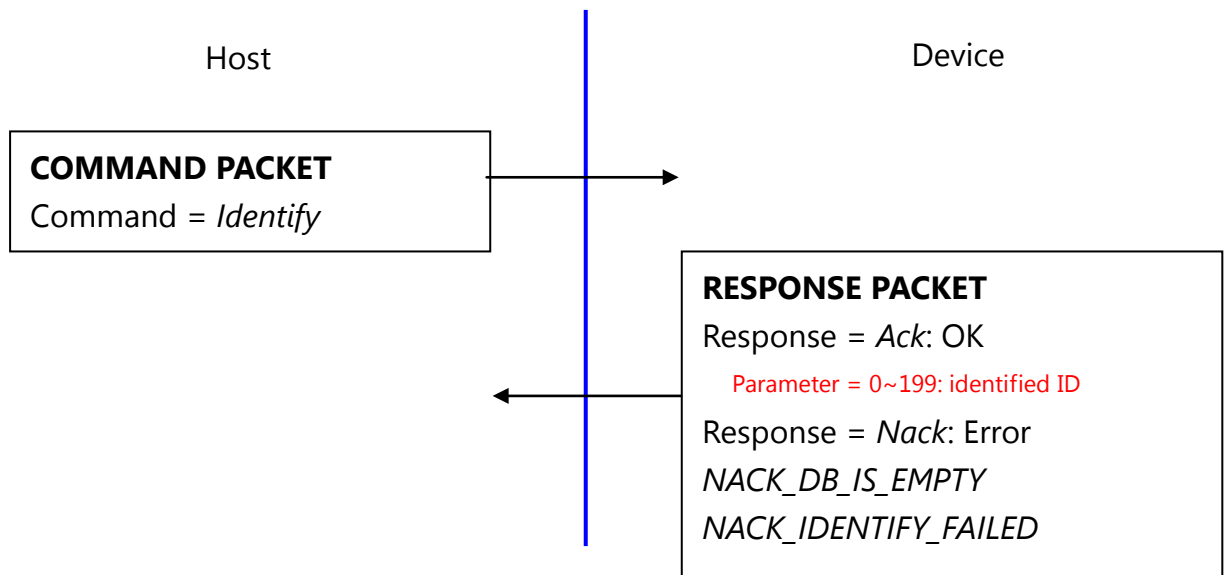

5.17. 1:1 Verification of Template(*VerifyTemplate*)

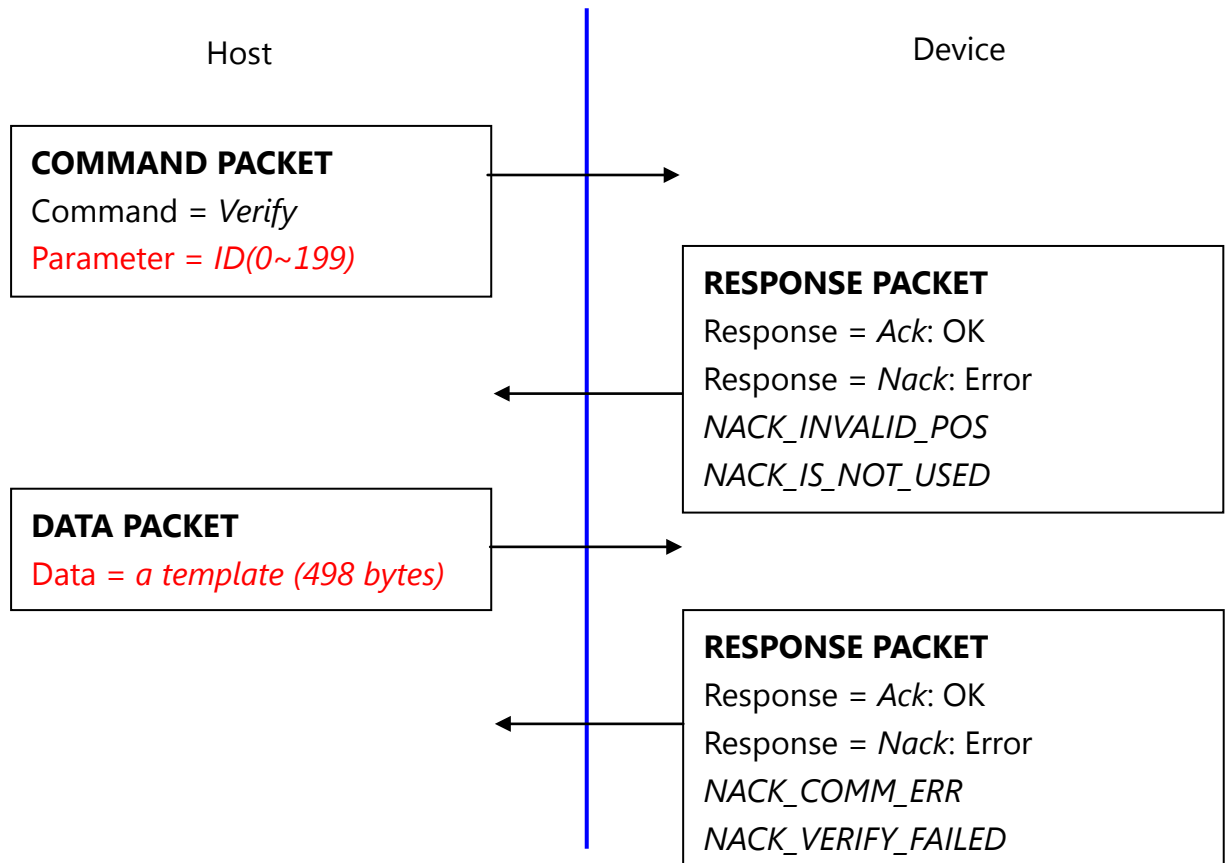

5.18. 1:N Identification of Template(*IdentifyTemplate*)

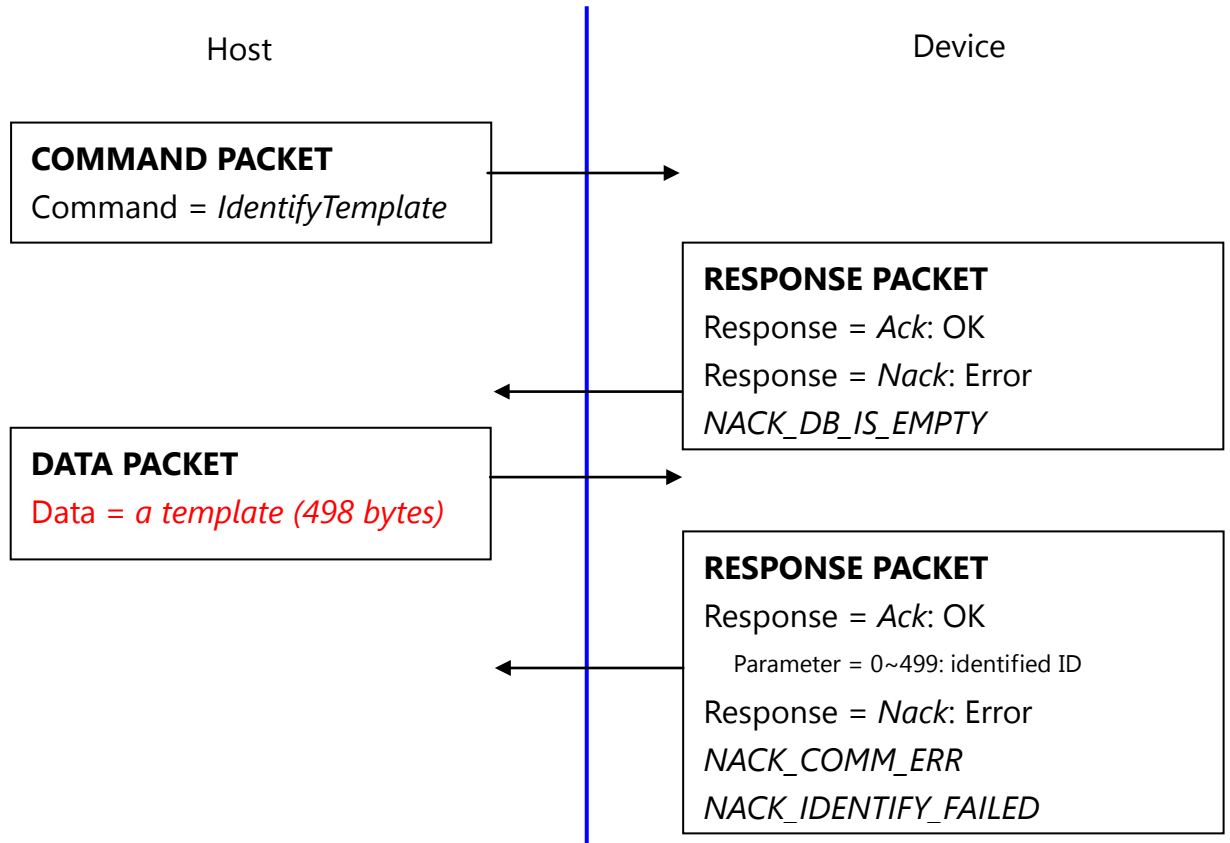

5.19. Capture fingerprint(*CaptureFinger*)

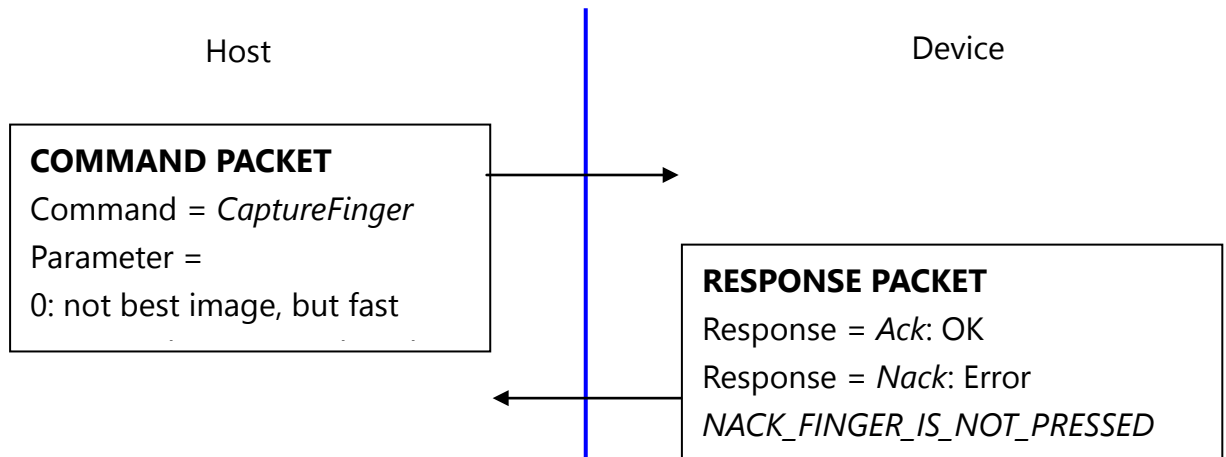

The fingerprint algorithm uses 450dpi 256x256 image for its input.

This command captures raw image from the sensor and converts it to 256x256 image for the fingerprint algorithm. If the finger is not pressed, this command returns with non-acknowledge.

Please use best image for enrollment to get best enrollment data.

Please use not best image for identification (verification) to get fast user sensibility.

5.20. Make Template(*MakeTemplate*)

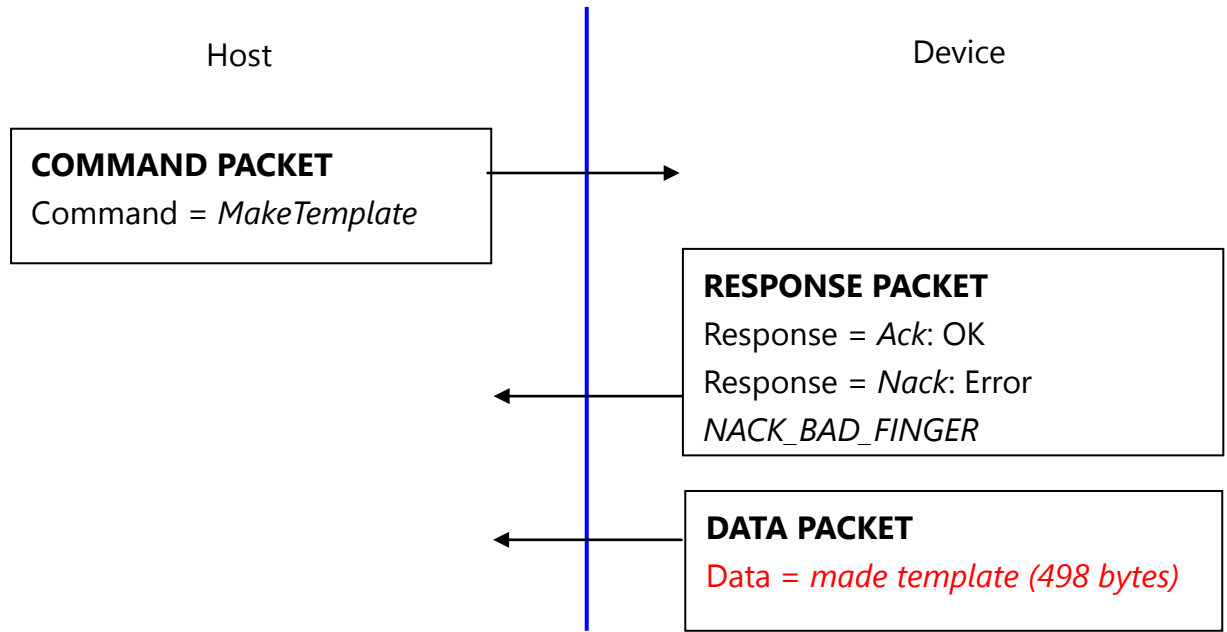

This function makes template for transmission. *CaptureFinger* command should be previously issued. Do not use the template for registration.

5.21. Get fingerprint image(*GetImage*)

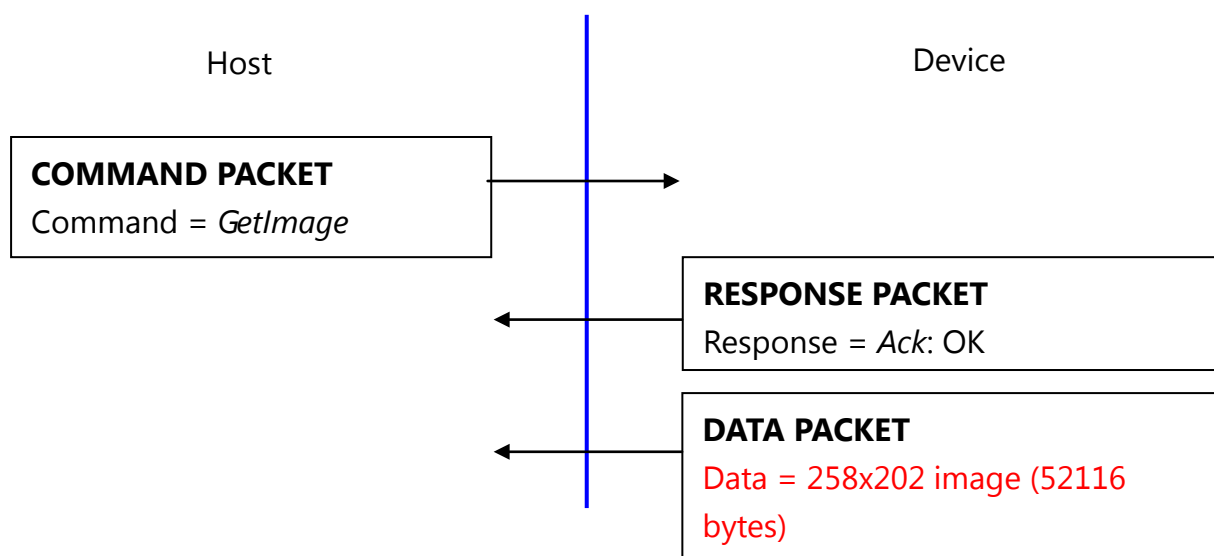

5.22. Get raw image(*GetRawImage*)

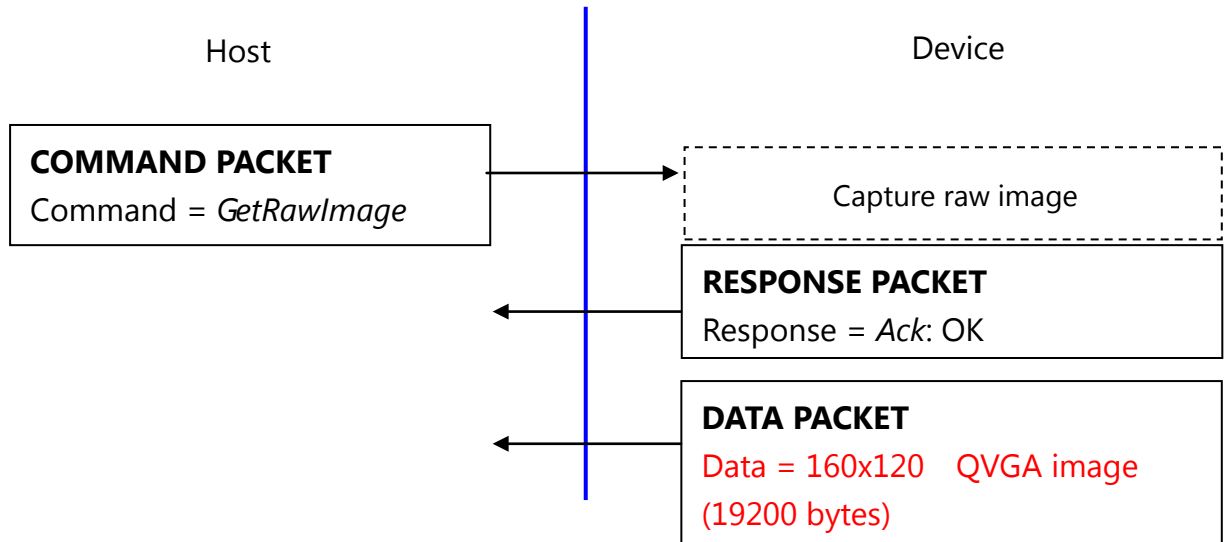

5.23. Get template(*GetTemplate*)

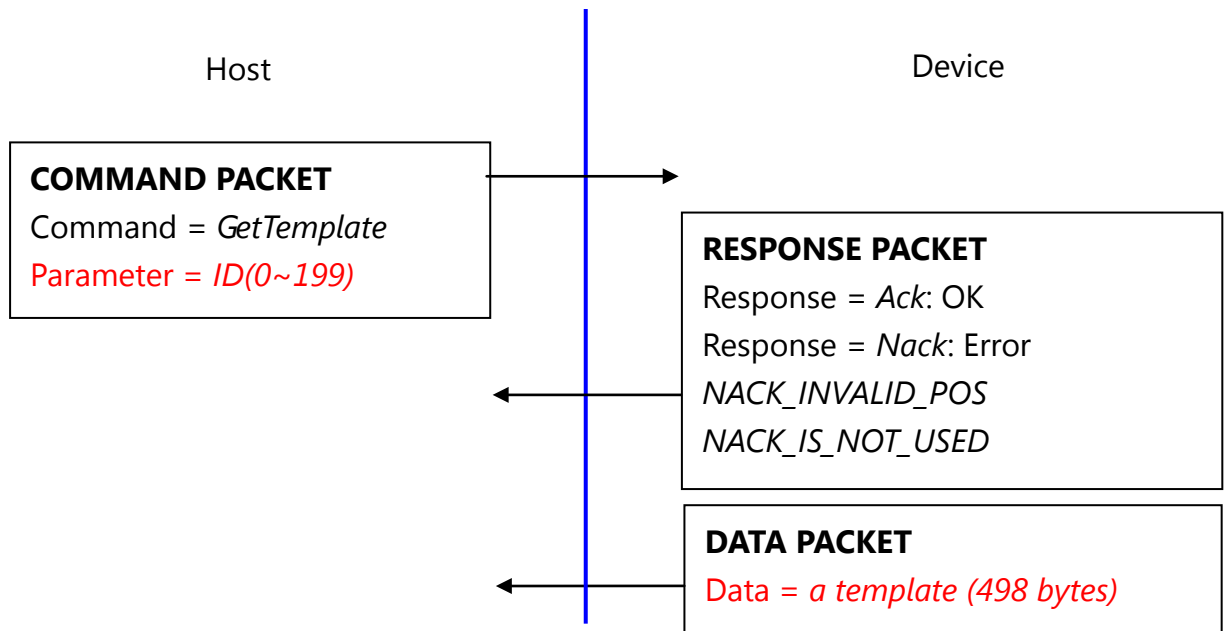

5.24. Set template(*SetTemplate*)

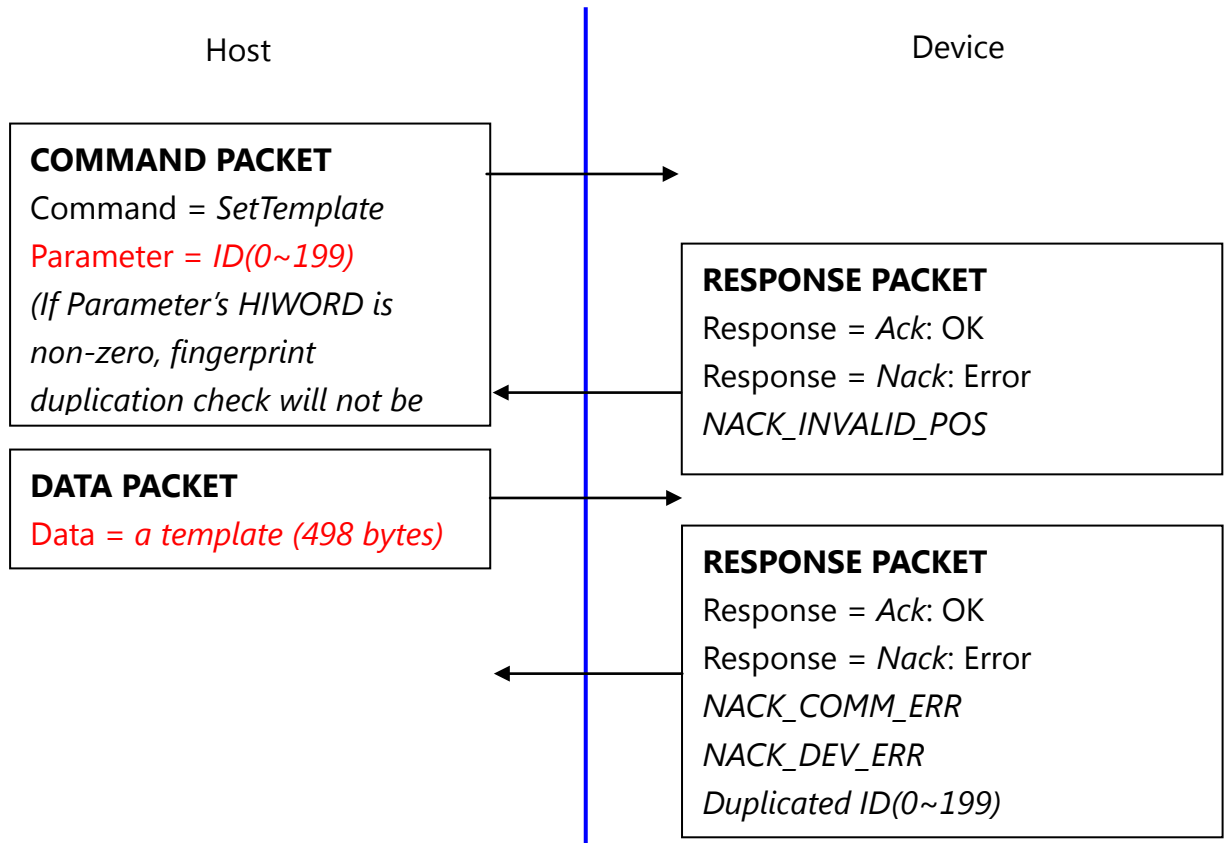

5.25. Start database download, obsolete(*GetDatabaseStart*)

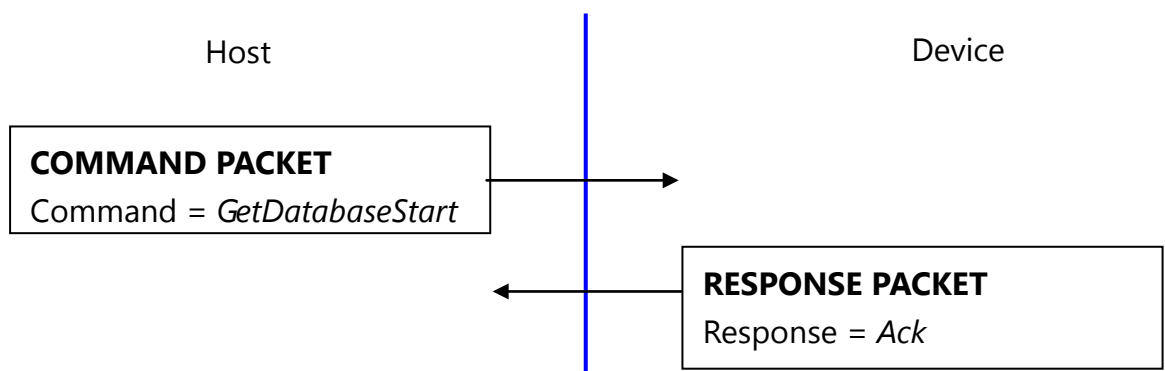

GetDatabaseStart command does nothing. It exists for historical reason; it was used for RS232 communication.

5.26. End database download, obsolete(*GetDatabaseEnd*)

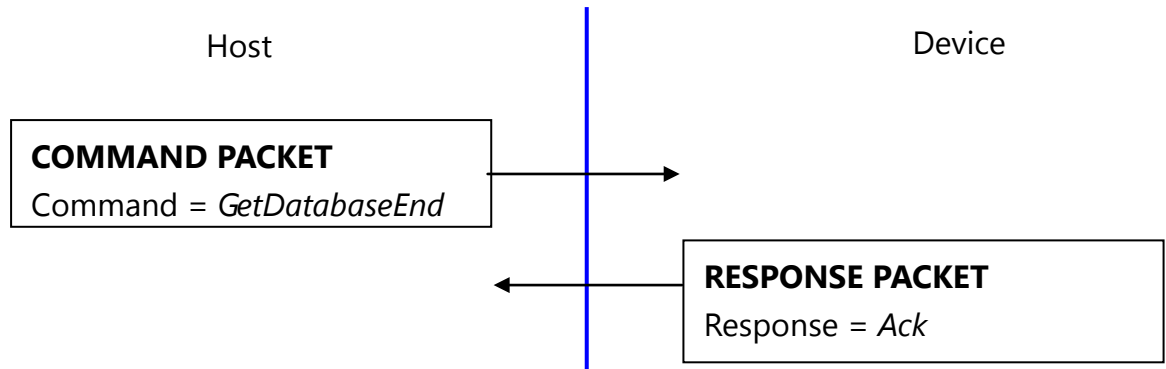

GetDatabaseEnd command does nothing. It exists for historical reason; it was used for RS232 communication.

5.27. Upgrade Firmware(*UpgradeFirmware*)

Not supported

5.28. Upgrade ISO CD Image(*UpgradeISOCDImage*)

Not supported

5.29. Set IAP Mode(*SetIAPMode*)

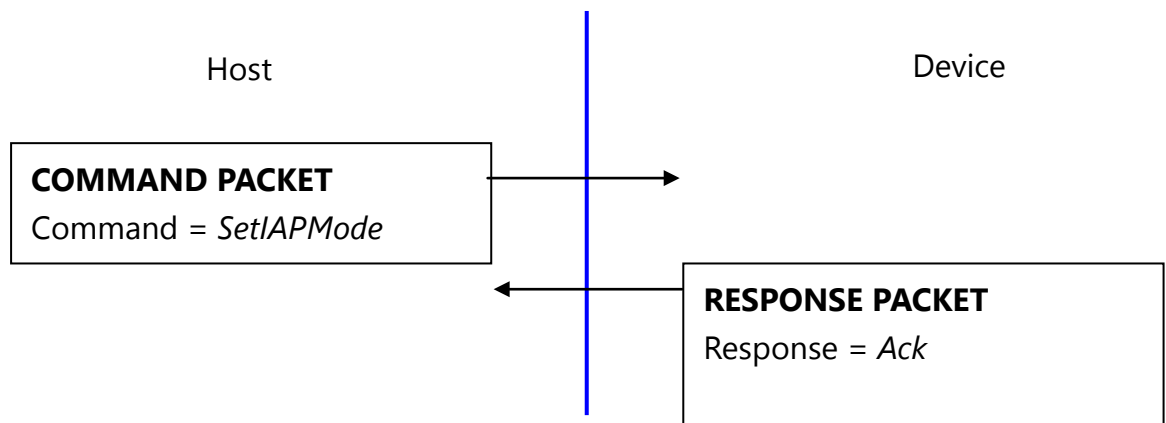

The Device enter in IAP Mode,
In this mode, FW upgrade is available.

6. Protocol: Flowchart, description

6.1 Capture of the fingerprint image

IsPressFinger checks whether a finger placed on the sensor. This function is used especially while enrollment.

CaptureFinger captures a fingerprint image (256x256), if a finger isn't placed on the sensor, it returns with error.

If this function returns with success, the device's internal RAM keeps valid fingerprint image for the subsequent commands. If the host issues other command, the fingerprint image will be used and destroyed.

GetRawImage captures a raw live image (320x240), it doesn't check whether a finger placed on the sensor, this function is used for debug or calibration.

6.2 Identifying and Verifying

Identify and *IdentifyTemplate* perform 1: N matching operation.

Verify and *VerifyTemplate* perform 1: 1 matching operation.

Just before calling of image-related matching functions (*Identify*, *Verify*), the host must call *CaptureFinger*.

6.3 Enrollment

An enrollment flowchart is as below.





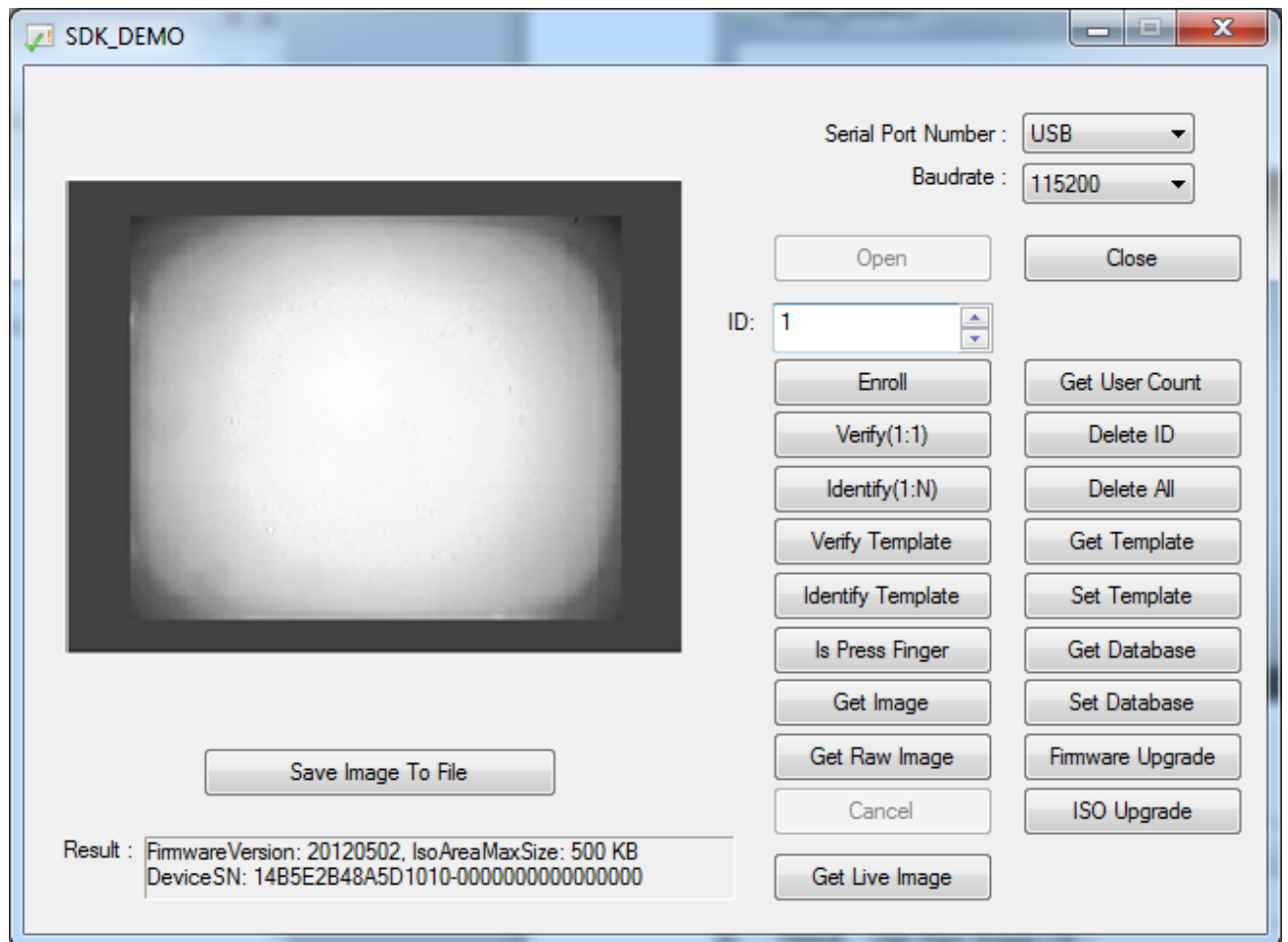

1. *EnrollStart* with a (not used) ID
2. *CaptureFinger*
3. *Enroll1*
4. Wait to take off the finger using *IsPressFinger*
5. *CaptureFinger*
6. *Enroll2*
7. Wait to take off the finger using *IsPressFinger*
8. *CaptureFinger*
9. *Enroll3*

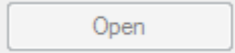
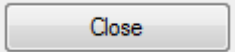
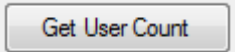
7. PC Demo

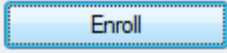
PC demo program describes how to use the device with its source code.

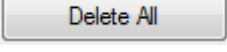
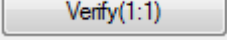
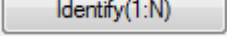
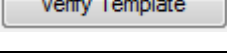
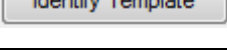
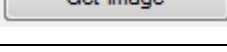
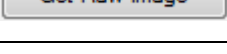

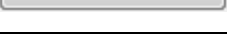
Command Alias	UI item to test it
<i>Open, UsbInternalCheck, ChangeBaudrate</i>	
<i>Close</i>	
<i>GetEnrollCount</i>	

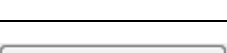
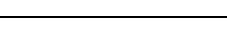
Command Alias	UI item to test it
<i>CheckEnrolled, EnrollStart, Enroll1, Enroll2, Enroll3, IsPressFinger</i>	 , 
<i>DeleteID</i>	
<i>DeleteAll</i>	
<i>Verify</i>	
<i>Identify</i>	
<i>VerifyTemplate</i>	
<i>IdentifyTemplate</i>	
<i>CaptureFinger, GetImage</i>	
<i>GetRawImage</i>	
<i>GetTemplate, GetDatabaseStart, GetDatabaseEnd</i>	 , 
<i>SetTemplate</i>	 
<i>UpgradeFirmware</i>	
<i>UpgradeISOCDImage</i>	

Demo program is supported with its source code.

The project is Microsoft Visual C++ 6.0 project.
We selected VC6.0 to minimize the size of the executable.

The demo program checks whether it is running on removable CD drive, if it is the case, it copies itself to "*My Document*" folder and executes copied version.
This is for direct access to the device's removable CD drive.

8. Mechanical Dimensions

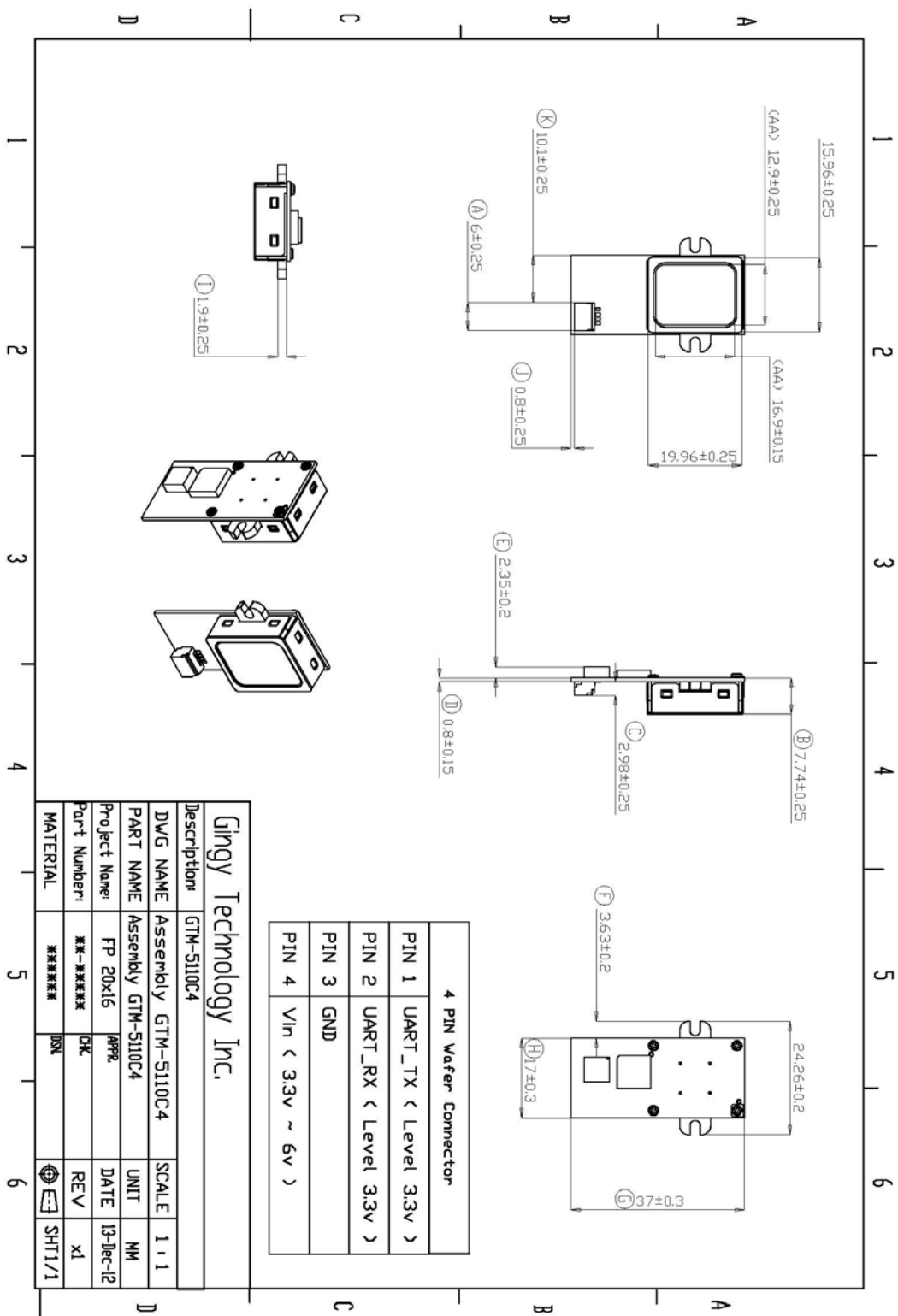

Copyright © 2012 Gingy Technology Inc.

All rights reserved.

Revision Information

This is the version 1.0 of this document, last updated on 2012/05/25

GINGY TECHNOLOGY INC.

NO.3 Creation Rd.II, Science Park, HsinChu 300,Taiwan,R.O.C.

TEL: 03-563-2500

<http://www.gingytech.com.tw>