



環天衛星科技股份有限公司

PRODUCT USER MANUAL
GPS RECEIVER ENGINE BOARD
EM-411

GlobalSat Technology Corporation

台北縣中和市建一路 186 號 16 樓(遠東世紀廣場)

16, No.186, Chien 1 Road, 235 Chung Ho City, Taipei Hsien, Taiwan ,R.O.C.

Tel: 886-2-8226-3799(Rep.)

Fax: 886-2-8226-3899

Web: www.globalsat.com.tw

E-mail: service@globalsat.com.tw

Features:

SiRF star III high performance GPS Chip Set

Very high sensitivity (Tracking Sensitivity: -159 dBm)

Extremely fast TTFF (Time To First Fix) at low signal level

Support NMEA 0183 data protocol

Built-in SuperCap to reserve system data for rapid satellite acquisition

Built-in patch antenna

LED indicator for GPS fix or not fix

LEDOFF:	Receiver switch off
LED ON:	No fixed, Signal searching
LED Flashing:	Position Fixed

Specification:

General

Chipset	SiRF Star III
Frequency	L1, 1575.42 MHz
C/A code	1.023 MHz chip rate
Channels	20 channel all-in-view tracking
Sensitivity	-159 dBm

Accuracy

Position	10 meters, 2D RMS 5 meters, 2D RMS, WAAS enabled
Velocity	0.1 m/s
Time	1us synchronized to GPS time

Datum

Default	WGS-84
---------	--------

Acquisition Time

Reacquisition	0.1 sec., average
Hot start	1 sec., average
Warm start	38 sec., average

Cold start 42 sec., average

Dynamic Conditions

Altitude 18,000 meters (60,000 feet) max
Velocity 515 meters /second (1000 knots) max
Acceleration Less than 4g
Jerk 20m/sec **3

Power

Main power input 4.5V ~ 6.5V DC input
Power consumption 60mA

Protocol

Electrical level TTL level, Output voltage level: 0V ~ 2.85V
RS-232 level
Baud rate 4,800 bps
Output message NMEA 0183 GGA, GSA, GSV, RMC, VTG, GLL

Physical Characteristics

Dimension 30mm*30mm*10.5mm ±0.3mm

Operating temperature -40°C to +85°C

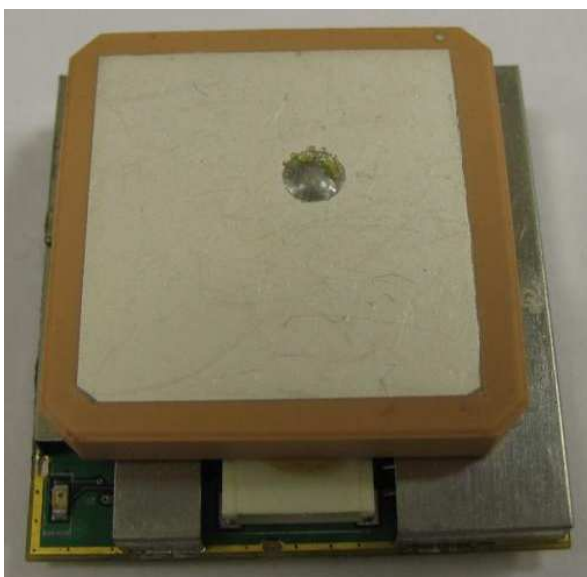

Pin Assignment

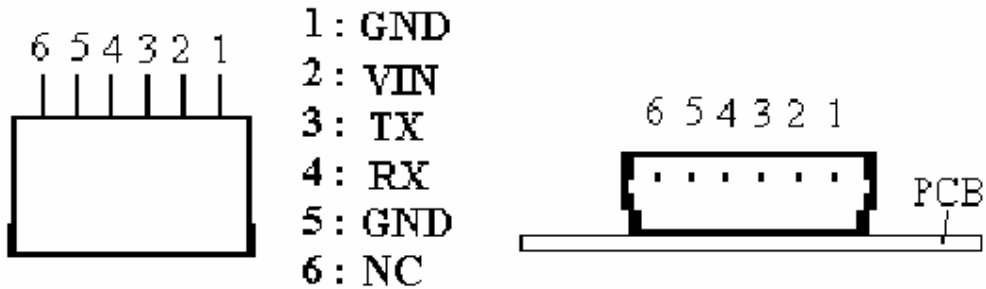

do not connect the pin 6

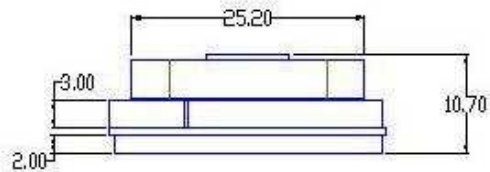
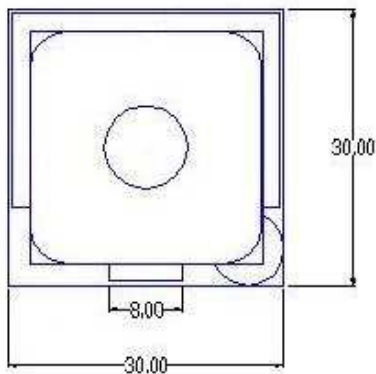

Dimension $\pm 0.3\text{mm}$

Pin description

*** VIN (DC power input):**

This is the main DC supply for a 4.5V ~6.5 DC input power.

*** TX:**

This is the main transmits channel for outputting navigation and measurement data to user's navigation software or user written software.

*** RX:**

This is the main receive channel for receiving software commands to the engine board from SiRFdemo software or from user written software.

*** GND:**

GND provides the ground for the engine board. Connect all grounds.

SOFTWARE COMMAND

NMEA Output Command

GGA-Global Positioning System Fixed Data

Table B-2 contains the values for the following example:

\$GPGGA,161229.487,3723.2475,N,12158.3416,W,1,07,1.0,9.0,M,,,0000*18

Table B-2 GGA Data Format

Name	Example	Units	Description
Message ID	\$GPGGA		GGA protocol header
UTC Time	161229.487		hhmmss.sss
Latitude	3723.2475		ddmm.mmmm
N/S Indicator	N		N=north or S=south
Longitude	12158.3416		dddmm.mmmm
E/W Indicator	W		E=east or W=west
Position Fix Indicator	1		See Table B-3
Satellites Used	07		Range 0 to 12
HDOP	1.0		Horizontal Dilution of Precision
MSL Altitude ¹	9.0	meters	
Units	M	meters	
Geoid Separation ¹		meters	
Units	M	meters	
Age of Diff. Corr.		second	Null fields when DGPS is not used
Diff. Ref. Station ID	0000		
Checksum	*18		
<CR><LF>			End of message termination

¹SiRF Technology Inc. does not support geoid corrections. Values are WGS84 ellipsoid heights.

Table B-3 Position Fix Indicator

Value	Description
0	Fix not available or invalid
1	GPS SPS Mode, fix valid
2	Differential GPS, SPS Mode, fix valid
3	GPS PPS Mode, fix valid

GLL-Geographic Position-Latitude/Longitude

Table B-4 contains the values for the following example:

\$GPGLL,3723.2475,N,12158.3416,W,161229.487,A*2C

Table B-4 GLL Data Format

Name	Example	Units	Description
Message ID	\$GPGLL		GLL protocol header
Latitude	3723.2475		ddmm.mmmm
N/S Indicator	n		N=north or S=south
Longitude	12158.3416		dddmm.mmmm
E/W Indicator	W		E=east or W=west
UTC Position	161229.487		hhmmss.sss
Status	A		A=data valid or V=data not valid
Checksum	*2C		
<CR><LF>			End of message termination

GSA-GNSS DOP and Active Satellites

Table B-5 contains the values for the following example:

\$GPGSA,A,3,07,02,26,27,09,04,15,,,,,1.8,1.0,1.5*33

Table B-5 GSA Data Format

Name	Example	Units	Description
Message ID	\$GPGSA		GSA protocol header
Mode1	A		See Table B-6
Mode2	3		See Table B-7
Satellite Used ¹	07		Sv on Channel 1
Satellite Used ¹	02		Sv on Channel 2
.....			
Satellite Used ¹			Sv on Channel 12
PDOP	1.8		Position dilution of Precision
HDOP	1.0		Horizontal dilution of Precision
VDOP	1.5		Vertical dilution of Precision
Checksum	*33		
<CR><LF>			End of message termination

1. Satellite used in solution.

Table B-6 Mode1

Value	Description
M	Manual-forced to operate in 2D or 3D mode
A	2Dautomatic-allowed to automatically switch 2D/3D

Table B-7 Mode 2

Value	Description
1	Fix Not Available
2	2D
3	3D

GSV-GNSS Satellites in View

Table B-8 contains the values for the following example:

\$GPGSV,2,1,07,07,79,048,42,02,51,062,43,26,36,256,42,27,27,138,42*71

\$GPGSV,2,2,07,09,23,313,42,04,19,159,41,15,12,041,42*41

Table B-8 GSV Data Format

Name	Example		Description
Message ID	\$GPGSV		GSV protocol header
Number of Messages ¹	2		Range 1 to 3
Message Number ¹	1		Range 1 to 3
Satellites in View	07		
Satellite ID	07		Channel 1(Range 1 to 32)
Elevation	79	degrees	Channel 1(Maximum90)
Azimuth	048	degrees	Channel 1(True, Range 0 to 359)
SNR(C/No)	42	dBHz	Range 0 to 99,null when not tracking
.....		
Satellite ID	27		Channel 4 (Range 1 to 32)
Elevation	27	Degrees	Channel 4(Maximum90)
Azimuth	138	Degrees	Channel 4(True, Range 0 to 359)
SNR(C/No)	42	dBHz	Range 0 to 99,null when not tracking
Checksum	*71		
<CR><LF>			End of message termination

Depending on the number of satellites tracked multiple messages of GSV data may be required.

RMC-Recommended Minimum Specific GNSS Data

Table B-10 contains the values for the following example:

\$GPRMC,161229.487,A,3723.2475,N,12158.3416,W,0.13,309.62,120598,,*10

Table B-10 RMC Data Format

Name	Example	Units	Description
Message ID	\$GPRMC		RMC protocol header
UTC Time	161229.487		hhmmss.sss
Status	A		A=data valid or V=data not valid
Latitude	3723.2475		ddmm.mmmm
N/S Indicator	N		N=north or S=south
Longitude	12158.3416		dddmm.mmmm
E/W Indicator	W		E=east or W=west
Speed Over Ground	0.13	knots	
Course Over Ground	309.62	degrees	True
Date	120598		ddmmyy
Magnetic Variation ²		degrees	E=east or W=west
Checksum	*10		
<CR><LF>			End of message termination

SiRF Technology Inc. does not support magnetic declination. All “course over ground” data are geodetic WGS48 directions.

VTG-Course Over Ground and Ground Speed

\$GPVTG,309.62,T,,M,0.13,N,0.2,K*6E

Name	Example	Units	Description
Message ID	\$GPVTG		VTG protocol header
Course	309.62	degrees	Measured heading
Reference	T		True
Course		degrees	Measured heading
Reference	M		Magnetic
Speed	0.13	knots	Measured horizontal speed
Units	N		Knots
Speed	0.2	Km/hr	Measured horizontal speed
Units	K		Kilometers per hour
Checksum	*6E		
<CR><LF>			End of message termination

NMEA Input Command

A). Set Serial Port ID:100 Set PORTA parameters and protocol

This command message is used to set the protocol(SiRF Binary, NMEA, or USER1) and/or the communication parameters(baud, data bits, stop bits, parity). Generally,this command would be used to switch the module back to SiRF Binary protocol mode where a more extensive command message set is available. For example,to change navigation parameters. When a valid message is received,the parameters will be stored in battery backed SRAM and then the receiver will restart using the saved parameters.

Format:

```
$PSRF100,<protocol>,<baud>,<DataBits>,<StopBits>,<Parity>*CKSUM  
<CR><LF>
```

<protocol>	0=SiRF Binary, 1=NMEA, 4=USER1
<baud>	1200, 2400, 4800, 9600, 19200, 38400
<DataBits>	8,7. Note that SiRF protocol is only valid f8 Data bits
<StopBits>	0,1
<Parity>	0=None, 1=Odd, 2=Even

Example 1: Switch to SiRF Binary protocol at 9600,8,N,1

```
$PSRF100,0,9600,8,1,0*0C<CR><LF>
```

Example 2: Switch to User1 protocol at 38400,8,N,1

```
$PSRF100,4,38400,8,1,0*38<CR><LF>
```

****Checksum Field:** The absolute value calculated by exclusive-OR the 8 data bits of each character in the Sentence,between, but excluding “\$” and “*”. The hexadecimal value of the most significant and least significant 4 bits of the result are converted to two ASCII characters (0-9,A-F) for transmission. The most

significant character is transmitted first.

**<CR><LF> : Hex 0D 0A

B). Navigation Initialization ID : 101 Parameters required for

start

This command is used to initialize the module for a warm start, by providing current position (in X, Y, Z coordinates), clock offset, and time. This enables the receiver to search for the correct satellite signals at the correct signal parameters. Correct initialization parameters will enable the receiver to acquire signals more quickly, and thus, produce a faster navigational solution.

When a valid Navigation Initialization command is received, the receiver will restart using the input parameters as a basis for satellite selection and acquisition.

Format :

\$PSRF101,<X>,<Y>,<Z>,<ClkOffset>,<TimeOfWeek>,<WeekNo>,<chnlCount>,<ResetCfg>

*CKSUM<CR><LF>

<X>	X coordinate position INT32
<Y>	Y coordinate position INT32
<Z>	Z coordinate position INT32
<ClkOffset>	Clock offset of the receiver in Hz, Use 0 for last saved value if available. If this is unavailable, a default value of 75000 for GSP1, 95000 for GSP 1/LX will be used. INT32
<TimeOf Week>	GPS Time Of Week UINT32
<WeekNo>	GPS Week Number UINT16

(Week No and Time Of Week calculation from UTC time)

<chnlCount> Number of channels to use.1-12. If your CPU throughput is not high enough, you could decrease needed throughput by reducing the number of active channels
UBYTE

<ResetCfg> bit mask
0x01=Data Valid warm/hotstarts=1
0x02=clear ephemeris warm start=1
0x04=clear memory. Cold start=1
UBYTE

Example: Start using known position and time.

\$ PSRF101,-2686700,-4304200,3851624,96000,497260,921,12,3*7F

C). Set DGPS Port ID:102 Set PORT B parameters for DGPS input

This command is used to control Serial Port B that is an input only serial port used to receive

RTCM differential corrections.

Differential receivers may output corrections using different communication parameters.

The default communication parameters for PORT B are 9600

Baud, 8data bits, 0 stop bits, and no parity.

If a DGPS receiver is used which has different communication parameters, use this command to allow the receiver to correctly decode the data. When a valid message is received, the parameters will be stored in battery backed SRAM and then the receiver will restart using the saved parameters.

Format:

\$ PSRF102,<Baud>,<DataBits>,<StopBits>,<Parity>*CKSUM<CR><LF>

<baud>	1200,2400,4800,9600,19200,38400
<DataBits>	8
<StopBits>	0,1
<Parity>	0=None,Odd=1,Even=2

Example: Set DGPS Port to be 9600,8,N,1
\$ PSRF102,9600,8,1.0*12

D). Query/Rate Control ID:103 Query standard NMEA message and/or set output rate

This command is used to control the output of standard NMEA message GGA, GLL, GSA, GSV RMC, VTG. Using this command message, standard NMEA message may be polled once, or setup for periodic output. Checksums may also be enabled or disabled depending on the needs of the receiving program. NMEA message settings are saved in battery backed memory for each entry when the message is accepted.

Format:

\$ PSRF103,<msg>,<mode>,<rate>,<cksumEnable>*CKSUM<CR><LF>

<msg>

0=GGA,1=GLL,2=GSA,3=GSV,4=RMC,5=VTG

<mode> 0=SetRate,1=Query

<rate> Output every <rate>seconds, off=0,max=255

<cksumEnable> 0=disable Checksum,1=Enable checksum
for specified message

Example 1: Query the GGA message with checksum enabled

\$ PSRF103,00,01,00,01*25

Example 2: Enable VTG message for a 1Hz constant output with checksum enabled

\$ PSRF103,05,00,01,01*20

Example 3: Disable VTG message

\$ PSRF103,05,00,00,01*21

E). LLA Navigation Initialization ID:104 Parameters required to start using Lat/Lon/Alt

This command is used to initialize the module for a warm start, by providing current position (in Latitude, Longitude, Altitude coordinates), clock offset, and time. This enables the receiver to search for the correct satellite signals at the correct signal parameters. Correct initialization parameters will enable the receiver to acquire signals more quickly, and thus, will produce a faster navigational solution.

When a valid LLANavigationInitialization command is received, the receiver will restart using the input parameters as a basis for satellite selection and acquisition.

Format:

```
$PSRF104,<Lat>,<Lon>,<Alt>,<ClkOffset>,<TimeOfWeek>,<WeekNo>,<ChannelCount>,<ResetCfg>*CKSUM<CR><LF>
```

<Lat>	Latitude position, assumed positive north of equator and negative south of equator float, possibly signed
<Lon>	Longitude position, it is assumed positive east of Greenwich and negative west of Greenwich Float, possibly signed
<Alt>	Altitude position float, possibly signed
<ClkOffset>	Clock Offset of the receiver in Hz, use 0 for last saved value if available. If this is unavailable, a default value of 75000 for GSP1, 95000 for GSP1/LX will be used. INT32
<TimeOfWeek>	GPS Time Of Week UINT32
<WeekNo>	GPS Week Number

UINT16

<ChannelCount> Number of channels to use. 1-12

UBYTE

<ResetCfg> bit mask 0x01=Data Valid warm/hot starts=1
0x02=clear ephemeris warm start=1
0x04=clear memory. Cold start=1
UBYTE

Example: Start using known position and time.

\$ PSRF104,37.3875111,-121.97232,0,96000,237759,922,12,3*37

F). Development Data On/Off ID:105 Switch Development Data Messages On/Off

Use this command to enable development debug information if you are having trouble getting commands accepted. Invalid commands will generate debug information that should enable the user to determine the source of the command rejection. Common reasons for input command rejection are invalid checksum or parameter out of specified range. This setting is not preserved across a module reset.

Format: \$ PSRF105,<debug>*CKSUM<CR><LF>

<debug> 0=Off,1=On

Example: Debug On \$ PSRF105,1*3E

Example: Debug Off \$ PSRF105,0*3F

G). Select Datum ID:106 Selection of datum to be used for coordinate Transformations

GPS receivers perform initial position and velocity calculations using an earth-centered earth-fixed (ECEF) coordinate system. Results may be converted to an earth model (geoid) defined by the selected datum. The default datum is WGS 84 (World Geodetic System 1984) which provides a worldwide common grid system that may be translated into local coordinate systems or map datums. (Local map datums are a best fit to the local shape of the earth and not valid worldwide.)

Examples:

Datum select TOKYO_MEAN

\$PSRF106,178*32

Name	Example	Units	Description
Message ID	\$PSRF106		PSRF106 protocol header
Datum	178		21=WGS84 178=TOKYO_MEAN 179=TOKYO_JAPAN 180=TOKYO_KOREA 181=TOKYO_OKINAWA
Checksum	*32		
<CR> <LF>			End of message termination